



SMA6C SERIES

High power density 600W TVS

Reverse Voltage - 26 to 100 Volts

Peak Pulse Power-600 Watts

A2010

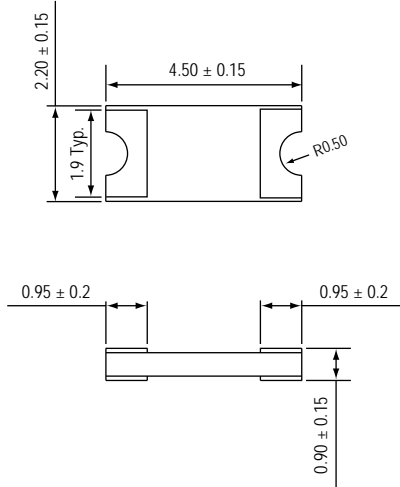

*Dimensions in millimeters

CoolTc™

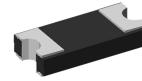

FEATURES

- * Halogen-free type
- * Compliance to RoHS product
- * Glass passivated chip
- * 600W surge capability in SMA equivalent package
- * Occupy only half the PCB area when compared to competitive TVS diodes in SMB packages
- * 600 W peak pulse power capability with a 10/1000 μ s waveform, repetitive rate (duty cycle) : 0.01%
- * Low leakage
- * Excellent clamping capability
- * Very fast response time

MECHANICAL DATA

Case : A2010

Terminals : Solder plated, solderable per MIL-STD-750, Method 2026

Polarity : Color band denotes positive end (cathode) except for bidirectional types

MAXIMUM RATINGS AND ELECTRICAL CHARACTERISTICS

*Ratings at 25°C ambient temperature unless otherwise specified.
single phase, half wave, 60Hz resistive or inductive load.
for capacitive load, derate current by 20%*

RATING	SYMBOL	VALUE	UNITS
Peak power dissipation with a 10/1000 μ s waveform	P _{PPM}	600	Watts
Peak pulse current with a 10/1000 μ s waveform	I _{PPM}	See next table	Amps
Power dissipation on infinite heatsink at T _L = 75	P _D	5.0	Watts
Operating junction and storage temperature range	T _J , T _{STG}	-55 to +150	

SMA6C SERIES

PART NUMBER	Marking Code	Working Peak Reverse Voltage V_{RWM} (V)	Breakdown Voltage V_{BR} @ I_T			Maximum Clamping Voltage V_C (V) @ I_{PP}	Maximum Reverse Surge Current I_{PP} (A) @ $10 \times 1000 \mu s$ sinewave	Maximum Reverse Leakage I_R (μA) @ V_{RWM}
			Min. (V)	Max. (V)	I_T (mA)			
BI-POLAR								
SMA6C26CAH	A6C 26CA•	26	28.9	31.9	1	42.1	14.25	1
SMA6C28CAH	A6C 28CA•	28	31.1	34.4	1	45.4	13.22	1
SMA6C30CAH	A6C 30CA•	30	33.3	36.8	1	48.4	12.40	1
SMA6C33CAH	A6C 33CA•	33	36.7	40.6	1	53.3	11.26	1
SMA6C36CAH	A6C 36CA•	36	40.0	44.2	1	58.1	10.33	1
SMA6C40CAH	A6C 40CA•	40	44.4	49.1	1	64.5	9.30	1
SMA6C43CAH	A6C 43CA•	43	47.8	52.8	1	69.4	8.65	1
SMA6C45CAH	A6C 45CA•	45	50.0	55.3	1	72.7	8.25	1
SMA6C48CAH	A6C 48CA•	48	53.3	58.9	1	77.4	7.75	1
SMA6C51CAH	A6C 51CA•	51	56.7	62.7	1	82.4	7.28	1
SMA6C54CAH	A6C 54CA•	54	60.0	66.3	1	87.1	6.89	1
SMA6C58CAH	A6C 58CA•	58	64.4	71.2	1	93.6	6.41	1
SMA6C60CAH	A6C 60CA•	60	66.7	73.7	1	96.8	6.20	1
SMA6C64CAH	A6C 64CA•	64	71.1	78.6	1	103	5.83	1
SMA6C70CAH	A6C 70CA•	70	77.8	86.0	1	113	5.31	1
SMA6C75CAH	A6C 75CA•	75	83.3	92.1	1	121	4.96	1
SMA6C78CAH	A6C 78CA•	78	86.7	95.8	1	126	4.76	1
SMA6C85CAH	A6C 85CA•	85	94.4	104	1	137	4.38	1
SMA6C90CAH	A6C 90CA•	90	100	111	1	146	4.11	1
SMA6C100CAH	A6C 100CA•	100	111	123	1	162	3.70	1

RATINGS AND CHARACTERISTIC CURVES

FIG. 1- PULSE DERATING CURVE

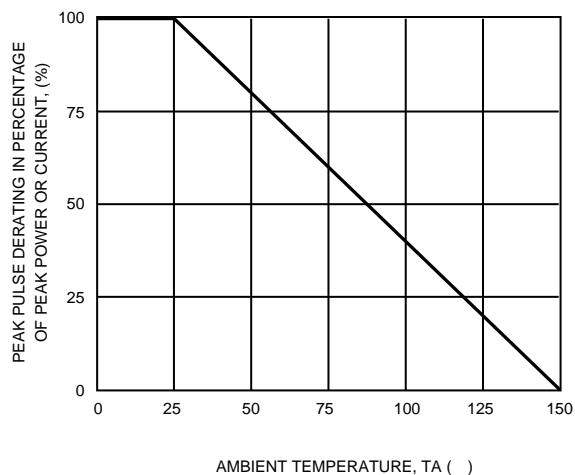

FIG. 2- STEADY STATE POWER DERATING CURVE

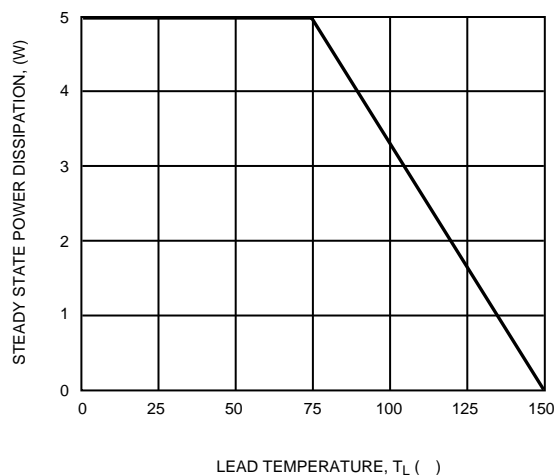

FIG. 3 - PEAK PULSE POWER RATING CURVE

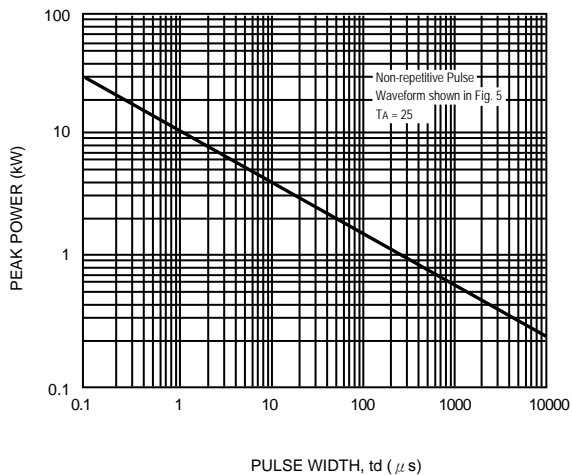

FIG. 4 - PULSE WAVEFORM

